

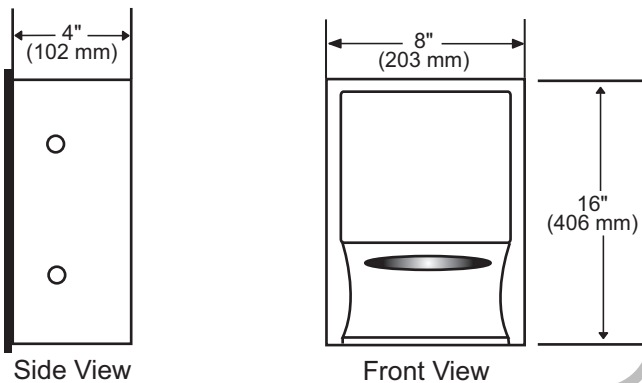

## **Model 200-SSLD Stainless Steel Liner Dispenser**

- 16 gauge, 304 brushed stainless steel liner dispenser.
- Mounts separately from changing station.
- Recessed mounting complies with A.D.A. 4.4.1, Maximum Protruding Objects when properly installed.
- Keyed lock prevents tampering or theft.
- Holds 100 liners.
- Holds item 036-LCR or 036-NWL.
- Standard pack: 1 unit.
- Limited Warranty: This product is warranted against manufacturing defects for a period of 5 years.

### **Product Dimensions**



### **Installation Information**

- Rough-in dimensions 8-3/16 inches (208 mm) wide x 16-3/16 inches (411 mm) high x 4-3/16 inches (106 mm) deep. Shim as required for tight fit on all 4 sides.
- Flange mounts flush against the wall.

### **Recommended Blocking**

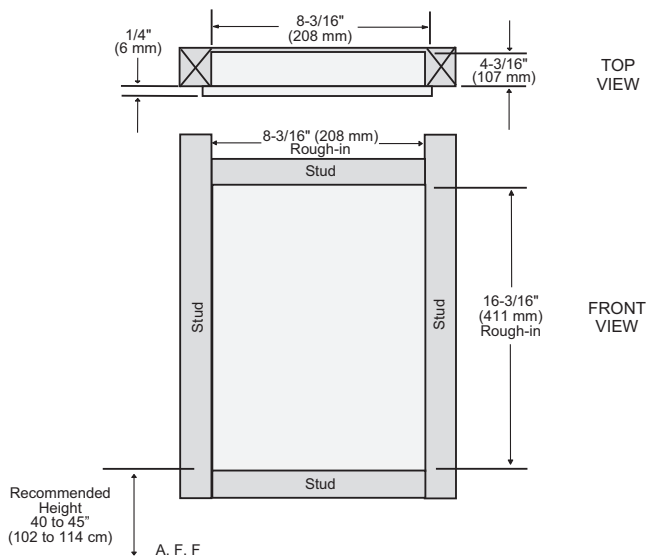

### **Short Specifications**

Stainless Steel Diaper Vendor:

1. Acceptable product: Foundations Worldwide, Inc.; Model 200-SSLD.
2. Characteristics:
  - a. 16 gauge, 304 brushed stainless steel.
  - b. Provide liners 036-LCR or 036-NWL .
3. **A.D.A. Compliance:**



4.4.1 Maximum Protruding Objects Compliant when properly installed.