

Model 100-SSV-R, 100-SSV-SM Vertical Stainless Steel Diaper Changing Station

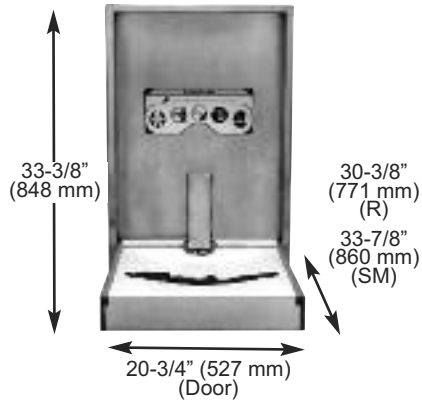

- Full body 16 gauge, 304 brushed stainless steel.
- Polystyrene replaceable tray liner.
- Safety belt with cam-buckle is adjustable with one hand.
- Full stainless steel frame and hinges provide maximum durability.
- Easy to read ANSI compliant labels (ANSI Z535.3 and ANSI Z535.4), utilizing universal safety symbols.
- Pneumatic gas shock mechanism to ensure smooth, safe open and close motions.
- Includes universal changing station door sign.
- Universal changing station plaque on front of unit.
- Surface mount requires additional flange. Specify model 100-SSV-SM.
- Limited Warranty: This product is warranted against manufacturing defects for a period of 5 years.

Recommended Blocking Recessed Mount

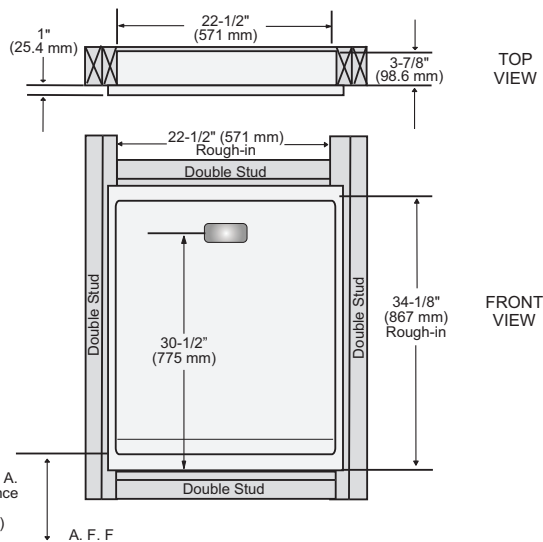

Short Specifications

Full 304 brushed stainless steel exterior with vacuum formed polystyrene changing surface.

1. A.D.A Compliant attached buckle.
2. Acceptable product: Foundations Worldwide, Inc.; Model 100-SSV-R (Vertical Recessed Mount) & 100-SSV-SM (Vertical Surface Mount).
3. Characteristics:
 - a. Entire body 16 gauge, 304 brushed stainless steel, seamless welds.
 - b. Provide Foundations Worldwide, Inc. SS-Flange in order to surface mount unit.
 - c. Provide Foundations Worldwide, Inc. 200-SSLD; stainless steel liner dispenser.
4. Equipped with a pneumatic cylinder.
5. Smooth nylon safety belt is easily cleaned.
6. Meets ASTM F2285 requirements for weight bearing Commercial Changing Stations.
7. **A.D.A. Compliance:**



4.4.1 Maximum Protruding Objects
4.27.4 Operation
Compliant when properly installed.

8. ANSI compliant safety labels.
9. CPSIA compliant to applicable sections.

Recommended Blocking Surface Mount

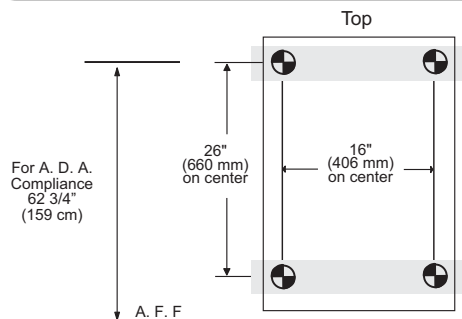

Installation Information

- 3.88 inches (98 mm) recessed into wall, 1 inch (25 mm) protrusion from wall. Unit projects 4 inches (100 mm) when surface mounted via model 100-SSV-SM.
- Rough-in opening 34.125 inches (867 mm) wide x 22.50 (571 mm) high. Shim as required for tight fit on all 4 sides. For recess mount, use side mounting holes.
- Open unit project from wall 30.375 inches (771 mm) when recessed and 33.875 inches (860 mm) when surface mounted.
- 3.5 inches (89 mm), 18 gauge metal studs minimum. Line studs with trimmed 2 x 4's.