

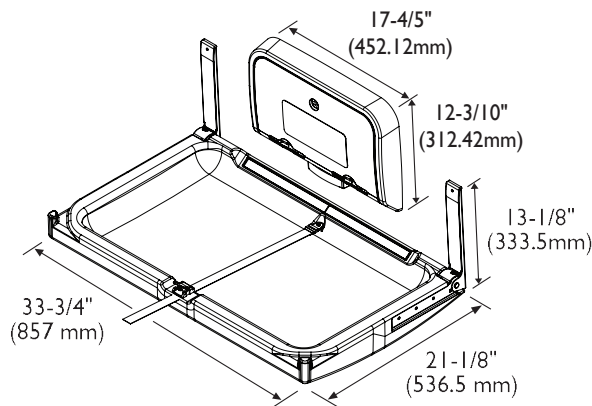

CHANGING STATIONS FOR A CHANGING WORLD.™

# Submittal Sheet

## Model 300-EHLD Horizontal Diaper Changing Station with Liner Dispenser



### Recommended Blocking

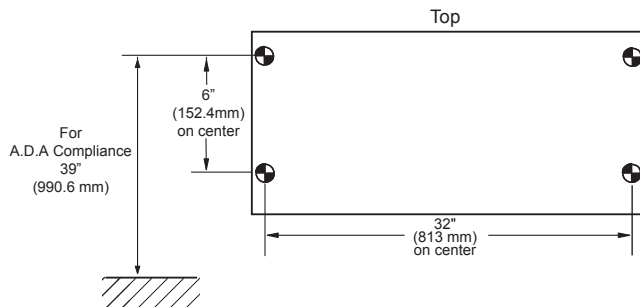

### Short Specifications

Polyethylene Diaper Changing Stations:

1. Acceptable product: Foundations Worldwide, Inc.; Model 300-EHLD.
2. Characteristics:
  - a. Type: Molded FDA approved high-density polyethylene (HDPE) body.
  - b. Smooth nylon belt with Thermoplastic Polyurethane coating. Easy to sanitize and adjustable.
  - c. Warning labels printed in English, Spanish and French.
  - d. Meets ASTM F2285 requirements for weight bearing Commercial Changing Stations.
3. A.D.A. Compliance:
 

306.3	Knee Clearance
307.2	Maximum Protruding Objects
308.2	Forward Reach
308.3	Side Reach
309.4	Operation
902.3	Work Surface

Compliant when properly installed.
4. ANSI compliant safety labels.
5. CPSIA compliant to applicable sections.
6. Meets or exceeds all requirements outlined by BS EN 12221:2008+A1:2013



- Easy to clean, high-density polyethylene which is naturally bacteria resistant.
- Smooth nylon belt with Thermoplastic Polyurethane coating. Easy to sanitize and adjustable.
- Convenient bag hooks on both sides.
- Easy to read ANSI compliant labels (ANSI Z535.3 and ANSI Z535.4), utilizing universal safety symbols.
- Compact, slim profile meets A.D.A when properly installed. Only protrudes 4 inches or 101 mm from wall.
- Includes universal changing station door sign.
- Torsion spring mechanism to ensure smooth, safe open and close motions.
- Steel-to-steel support hinges.
- Includes easy to use assembly template plus all mounting hardware allowing for one-person installation.
- ASTM G21 Anti-Bacterial: No measurable bacterial growth.
- Meets or exceeds ASTM F2285 Safety Specifications for Commercial Changing Stations.
- Standard pack: 1 unit.
- Limited Warranty: This product is warranted against manufacturing defects for a period of 5 years.
- Can be installed on any building code approved load bearing wall.
- Key lockable dual liner dispenser.
- Each liner dispenser holds approximately 50 of the 036-LCR or 036-NWL liners.

### Installation Information

- Closed unit projects less than 4 inches (101 mm) from wall.
- Open changing surface projects 21 inches (535 mm) from wall during use.
- Overall closed dimensions are 33-3/4 inches (856 mm) wide and 21 inches (535 mm) tall.
- Hardware allows for mounting to current or new construction applications.